



BAT
Coordinate Definition and
BAT Detector Layout

14 Apr 2006, Ver 1.3

Craig Markwardt
(based on work by)
Scott Barthelmy
NASA GSFC
Code 661



Version Record:

Version Number	Version Date	Comments
1.2	06 Nov 2004	This document was drawn from BAT Coordinate Definitions (v1.10) and BAT CZT Pixel Numbering vs Location Hierarchy (v1.1).
1.3	14 Apr 2006	Some formatting changes in the figures to make more of the labels visible.

The color code above is used throughout the document (to allow the reader to quickly find the changes from the current and previous versions).

1. Introduction

This document describes the BAT coordinate systems and detector layout. It is a combination of two documents,

BAT Coordinate Definitions (v1.10); and

BAT CZT Pixel Numbering vs Location Hierarchy (v1.1)

The purpose for merging the two documents is to combine the two sources of related information, primarily for public consumption. The "BAT Coordinate Definitions" document contains extra debate about various coordinate systems which is not relevant for the general public.

2. 3-Dimensional Coordinate Definitions

These are the 3 acceptable coordinate systems to be used by the BAT team. There are defined verbally below, however, people should refer to the "CZT Numbering-vs-Location and Coordinate System Definition" section of this document for the pictorial (and final) definitions.

1) BAT Coordinate System: It is a right-hand X,Y,Z Cartesian system. The +Z axis is the direction BAT looks (i.e. the photons received are traveling in the -Z direction). The X and Y axes are parallel to the plane of the DAP. The +Y is towards the XRT & UVOT (the short dimension of the DAP) and the +X direction is towards star cameras on XRT (the DAP long dimension).

It is a normal right-hand Cartesian coordinate system. The X=0,Y=0 origin is in the geometric center of the array of CZT (the intersection of Blocks 3,4,11&12). The Z=0 plane is 0.15 cm below the bottom surface (anode) of the CZT. This coordinate system is used for ALL activities involving the CZT (i.e. at the CZT detector level [4x4x2mm piece]), at the Sandwich level, the DM level, the Block level, the Array level, and the BAT Instrument level. The X,Y=0,0 center will always be the center of the configuration of the CZT being used (e.g., the center of an 8x16 sub-array of the Sandwich, the center of the DM, and of a Block). See Fig 1.

The units for the BAT XYZ system are centimeters.

Software and data files should refer explicitly to these coordinates as BAT_X, BAT_Y and BAT_Z.

2) Flight Software Science Coordinates: It is a spherical angle based system. Theta is the angle measured from the BAT +Z axis (i.e. the boresight). Phi is measured clockwise from the BAT +X axis. This is the coordinate system used by the BAT flight software. See Fig 2.

The Theta and Phi coordinates are reported in the TDRSS position message.

The origin of coordinates is within the BAT Mask, **not** the BAT_X/Y/Z origin. The array-to-mask distance used by the flight software for flight imaging is stored in housekeeping parameter BBRIIMGFLENGTH in housekeeping apid 0x161, in meters).

The units for all flight software angle specifications (i.e. more than just the BAT Science Coordinates) are in decimal degrees.

3) S/C Coordinate System: It is an X,Y,Z Cartesian system. The +X axis is the direction the 3 instruments look (i.e. the photons received are traveling in the -X direction). The Y and Z axes are parallel to the surface of the DAP -- the +Z is towards the XRT and UVOT (towards the Sun) and the +Y direction is towards XRT (i.e. UVOT is the -Y direction).

It is a normal right-hand Cartesian coordinate system. The Y=0,Z=0 position appears to be on the axis of the rocket (which appears to be on the midline of BAT and is about 1 inch inside the in-board edge of the Mask). The X=0 position is the plane between the top of the PAF and the bottom of the s/c. See Fig 3.

3. Image Coordinate Definitions

1) BAT detector images: detector images are binned in pixels, which are 4.2 mm x 4.2 mm. This bin size exactly matches the detector pitch spacing in the array. Cells where there are no detectors contain zero counts.

The detector image coordinates are DETX and DETY, which are parallel to BAT_X and BAT_Y, respectively. Pixel numbers start with zero. DETX=DETY=0 refers to the corner detector of the array which has the most negative BAT_X and BAT_Y position.

2) BAT sky images are initially computed as a tangent plane projection. The image axes are aligned with the detector axes, not the sky axes. The tangent plane coordinates are IMX and IMY. If a point is located at position BAT_X/Y/Z, then $IMX=BAT_X/BAT_Z$ and $IMY=BAT_Y/BAT_Z$.

3) BAT sky images can have sky coordinates attached. If the spacecraft attitude and instrument-to-spacecraft alignment are known, then the batftimage task will assign celestial (WCS) coordinates to the image. The image pixels are not changed, so the RA/Dec sky axes will typically be misaligned with the image axes.

BAT XYZ Coordinates

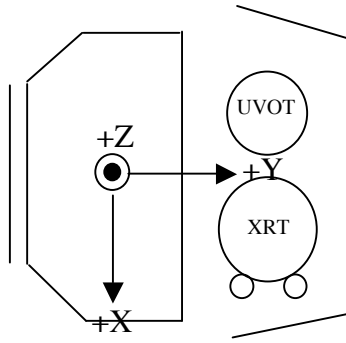

Fig 1. BAT XYZ Cartesian Coordinates Definition.

Science Coordinates

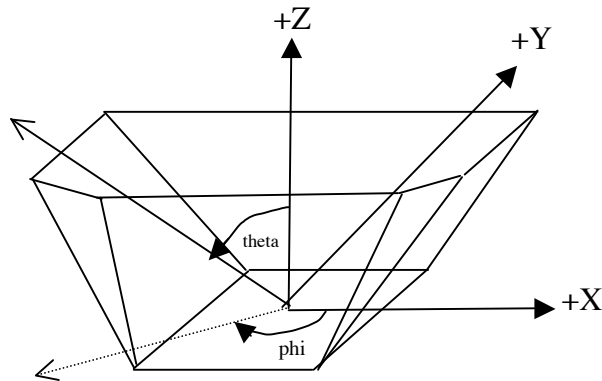

Fig 2. Flight Software Science Coordinate (Theta and Phi).

Spacecraft XYZ Coordinates

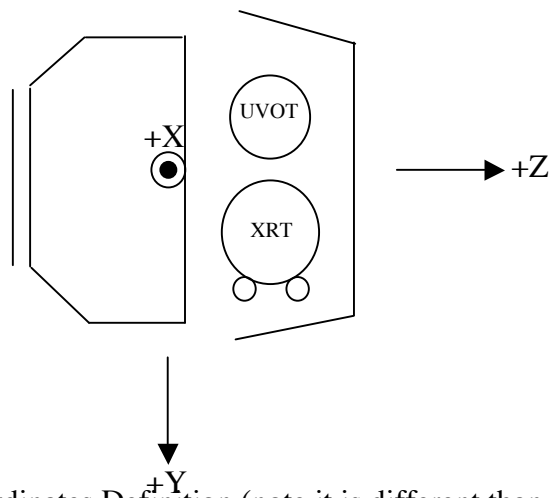
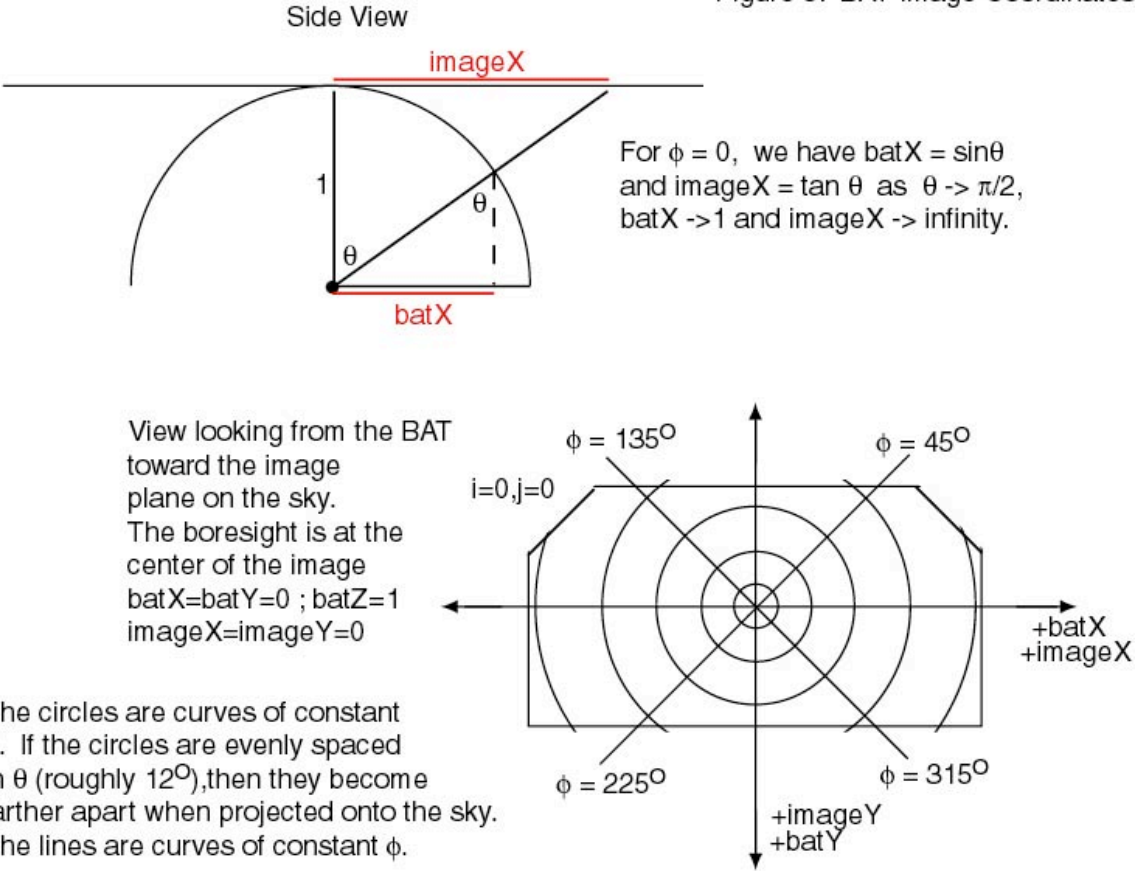

Fig 3: S/C XYZ Cartesian Coordinates Definition (note it is different than BAT XYZ).

Figure 5. BAT Image Coordinates



4. COMPARISON OF DIFFERENT COORDINATE SYSTEMS:

The table below shows the conversions between the different coordinate systems described in the document.

	BAT Coords	S/C Coords	FSW Coords	Image Coords	Grmc Coords
BAT Coords (Cartesian)	batX= 0 array ctr batY= 0 array ctr batZ= 0 @ 0.15 cm below CZT anode	batX=scY batY=scZ+22.5 batZ=scX-68.845 (units cm)	batX=sin(θ)cos(φ) batY= -sin(θ)sin(φ) batZ= cos(θ)+100 (units cm)	Convert through FSW Coords	Convert through FSW Coords
S/C Coords (Cartesian, rotated with respect to BAT Coords)	scX=batZ+68.845 scY=batX scZ=batY-22.5 (units cm)	scX=0 @ batZ = -68.845 cm scY=0 array ctr scZ=0 @ batY=22.5 cm	Convert through BAT Coords	Convert through BAT Coords	Convert through BAT Coords
FSW Coords (Polar in the image plane; pole is batZ-axis)	$\theta = \arcsin(\sqrt{\text{batX}^2 + \text{batY}^2})$ $\phi = \arctan(-\text{batY}/\text{batX})$	Convert through BAT Coords	$\theta = 0$ boresight $\phi = 0$ on +batX-axis, increases toward -batY	$\theta = \arctan(\sqrt{\text{imX}^2 + \text{imY}^2})$ $\phi = \arctan(-\text{imY}/\text{imX})$	Convert through image Coords
Image Coords (2-d Cartesian in the image plane)	Convert through FSW Coords	Convert through BAT Coords	$\text{imX} = \sqrt{\tan(\theta)^2 / (1 + \tan(\phi)^2)}$ $\text{imY} = -\tan(\phi)/\text{imX}$	imX=0 boresight imY=0 boresight	$\text{imX} = \tan(\text{lat}) / \cos(\text{lon})$ $\text{imY} = -\tan(\text{lon})$
Grmc Coords (Spherical; pole is batX-axis)	Convert through image Coords	Convert through BAT Coords	Convert through image Coords	lon = arctan(-imY) lat = arctan(imX * cos(lon))	lon= 0 on batY-axis lat= 0 on batX-axis

NOTE: The numerical quantities in the table above are approximate. They may change based on ground or on-orbit calibrations. The table is provided for overview information only.

5. Detector Layout

The following figures show the layout of the CZT detectors on the BAT detector array.

Block Number vs Location in the DAP

Note that all diagrams are drawn looking down from the Mask towards the DAP (i.e. the direction the photons go).

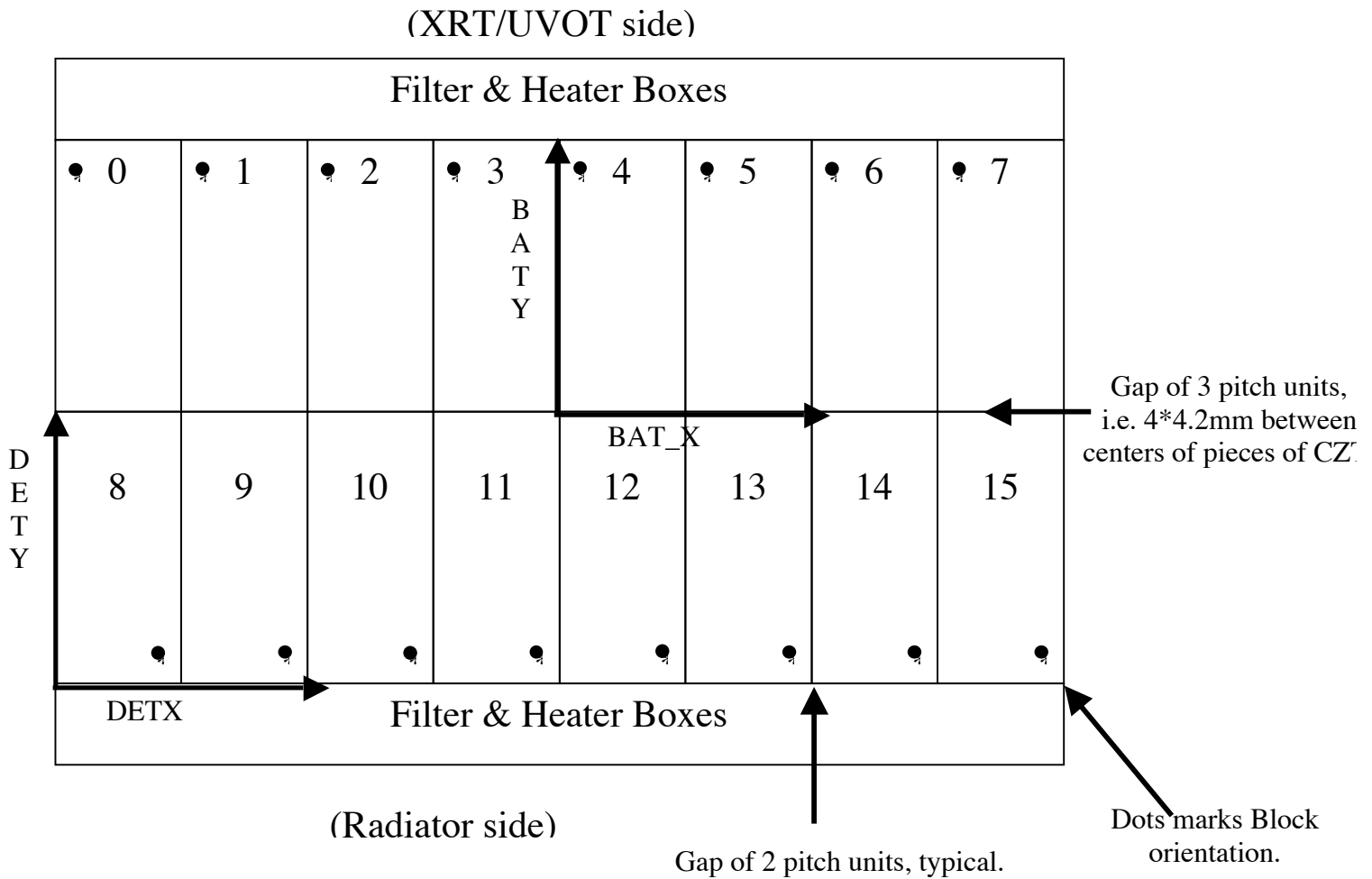

Note: The 0-15 designations for the Block identity are also sometimes referred to by 0-F, respectively (i.e. decimal numbers vs hexadecimal numbering designations).

XA1 Number vs Location in the Block

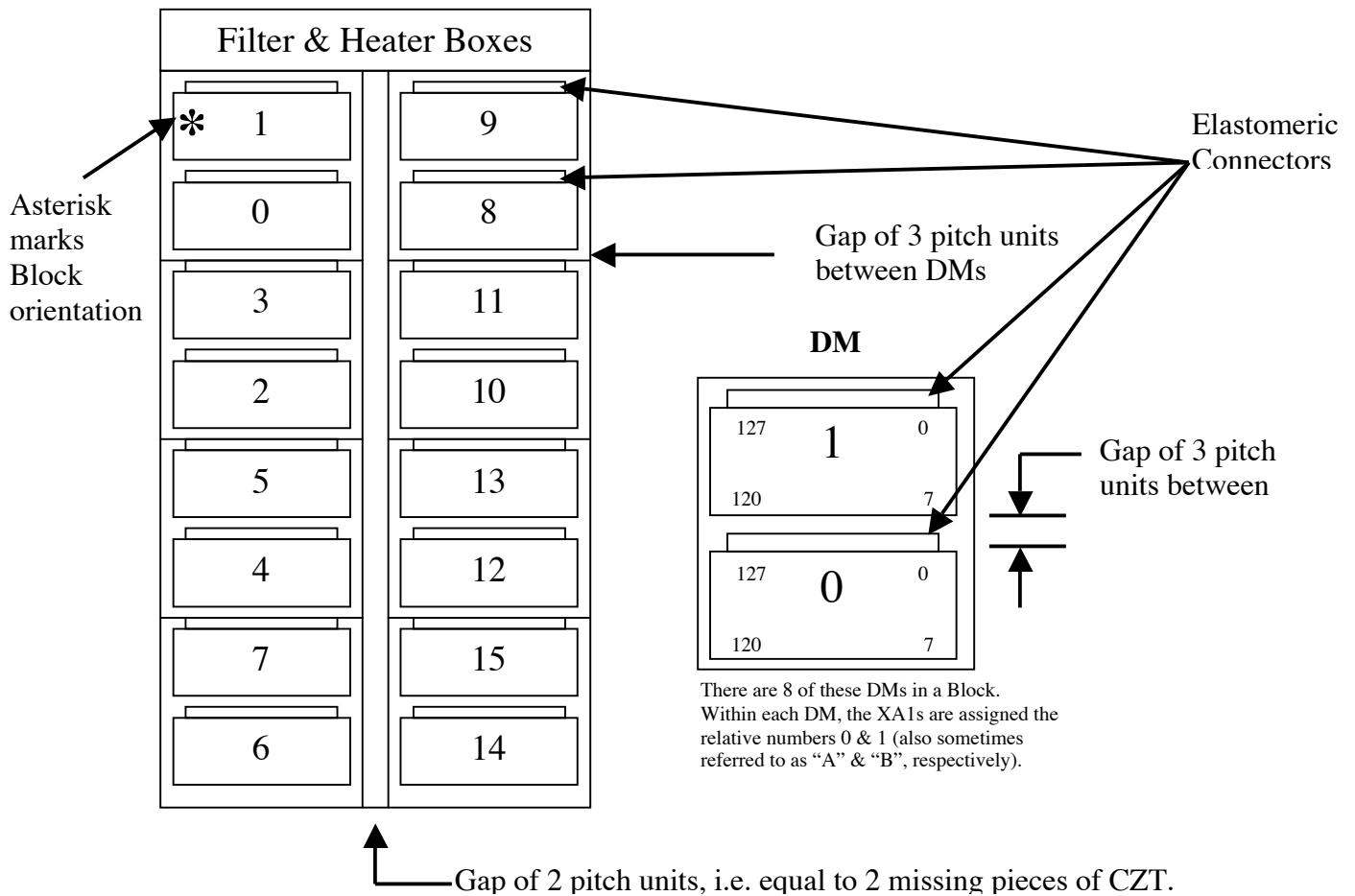

The asterisk in the upper right corner of the Block denotes the corner with the XA1 S/N=1 corner. This orientation designation for each Block is the same as the asterisks shown in the corners of the 16 Blocks in the DAP. Note that for the 8 Blocks in the upper half of the DAP, the asterisk is towards the upper left. But for the 8 Blocks in the lower half of the DAP (the Radiator side), the orientation of the Blocks puts that corner of the Block towards the lower right, because those 2nd set of 8 Blocks are rotated 180 deg wrt to the 1st set of 8 Blocks.

XA1 Number	vs	DM Number	XA1 Num	vs	DM Num
1 (=B)		0	9 (=B)		4
0 (=A)		0	8 (=A)		4
3 (=B)		1	11 (=B)		5
2 (=A)		1	10 (=A)		5
5 (=B)		2	13 (=B)		6
4 (=A)		2	12 (=A)		6
7 (=B)		3	15 (=B)		7
6 (=A)		3	14 (=A)		7

Sandwich Numbering Layout

As-Built

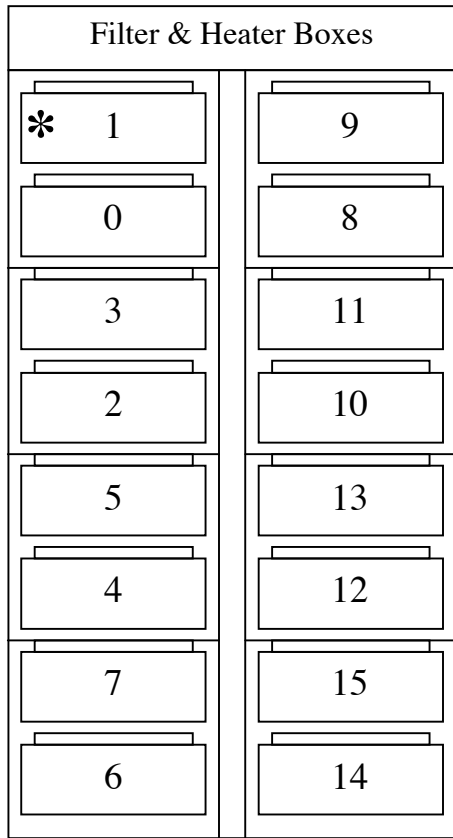

(This is what we fly.)

Desired

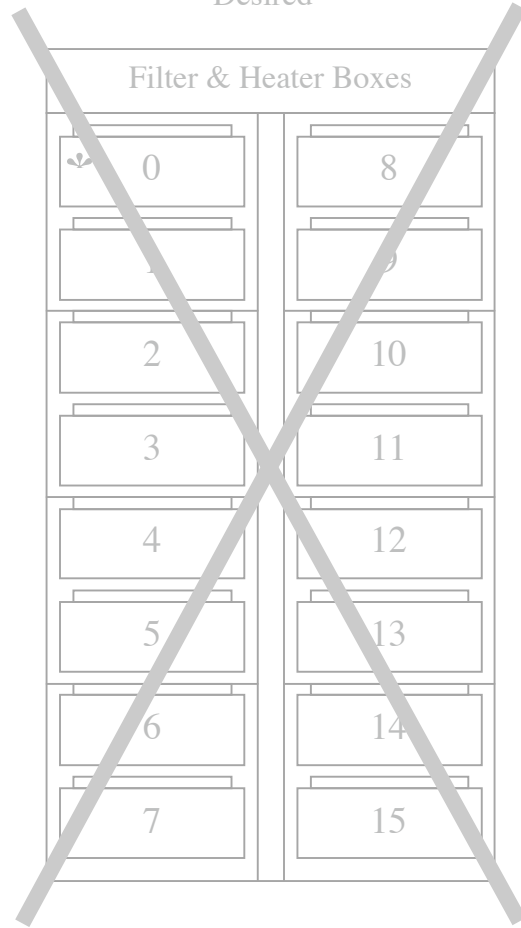

(This “desired” layout is shown only for historical purposes.)

(The only difference is in the swapping of the “A” and “B” sides within each DM.)

XA1 Channel Numbering (i.e. CZT pixel numbering)

vs

Location in the 8x16 Sub-Array

Sandwich

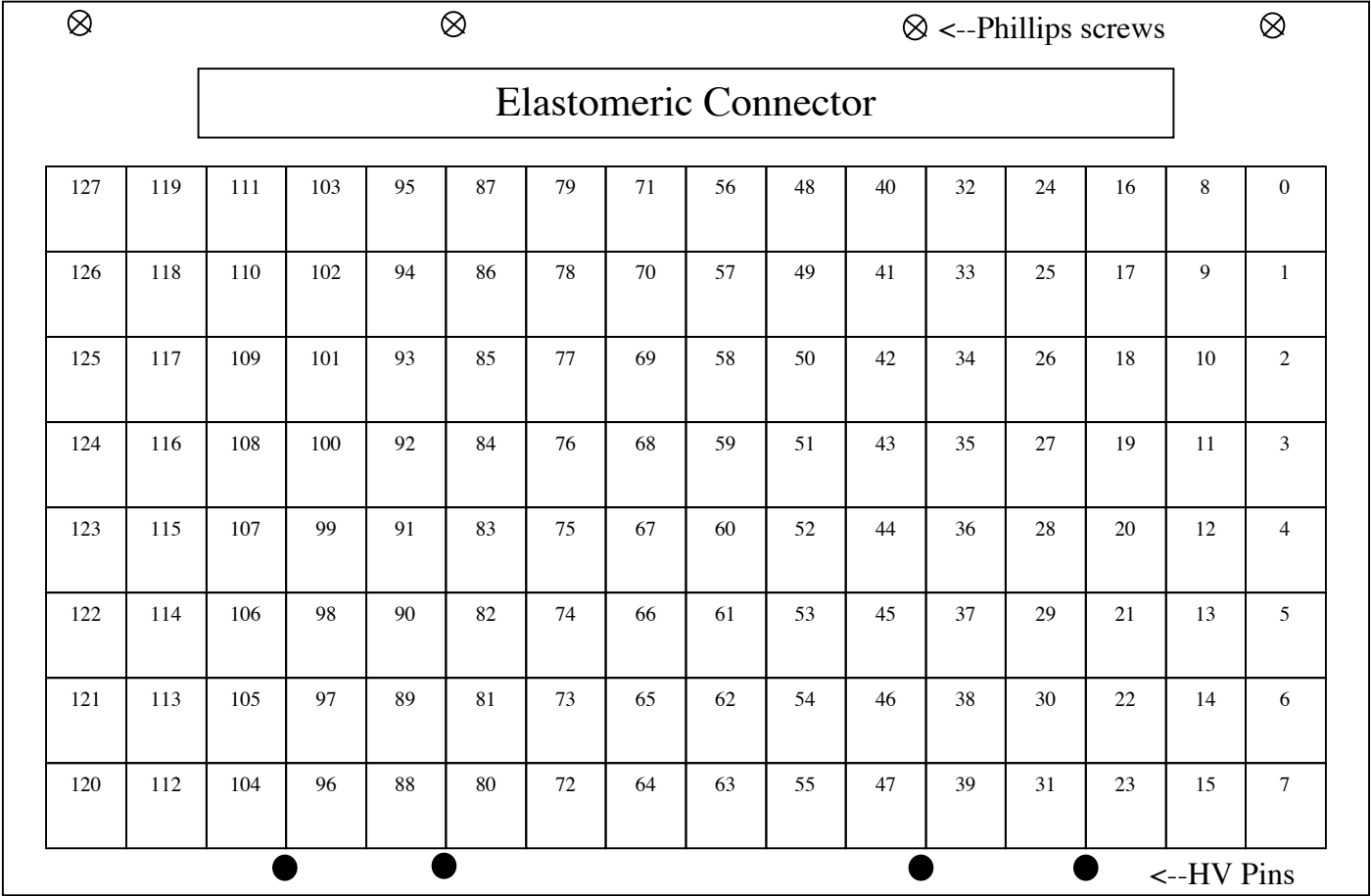

Note that all diagrams are drawn looking down from the Mask towards the DAP (i.e. the direction the photons go).

Note that the up/down ordering of the numbers switches at the mid-line of the 8x16 sub-array.

XA1VR connectors,

Looking down, X-ray view to see all the pertinent connectors.

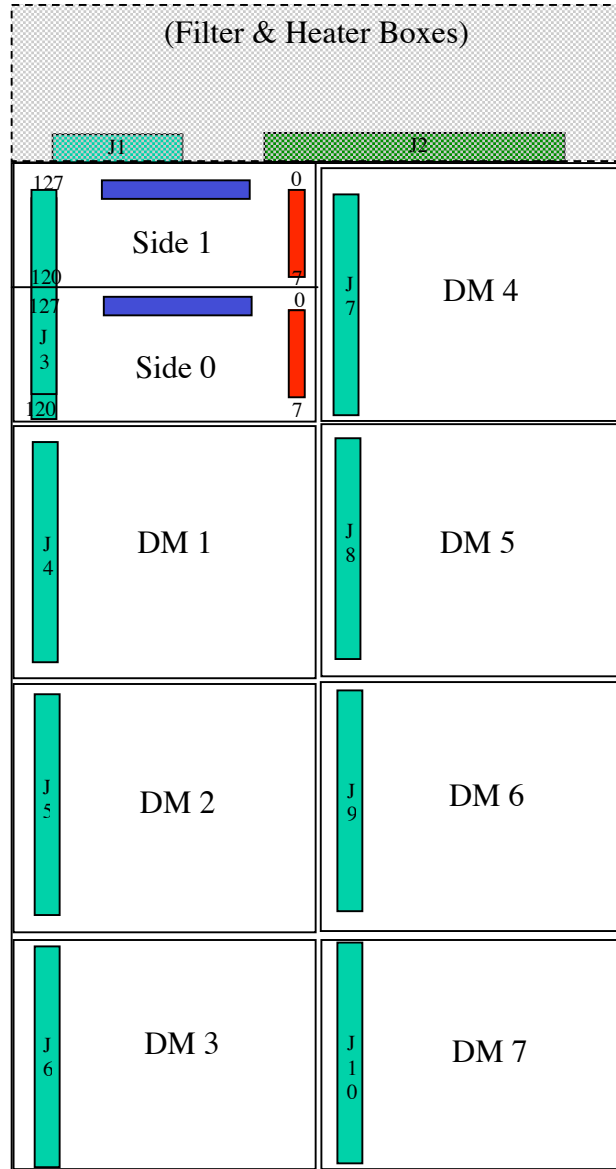

Elastomeric connectors

Samtec connectors

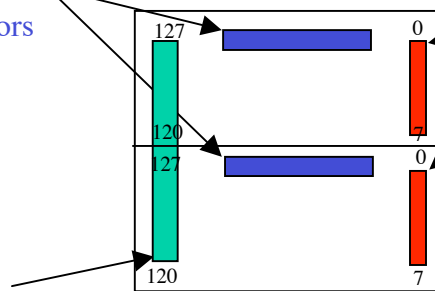

DM Connectors,
Looking down,
X-ray view to see them all.