	<b>Note on Hitomi attitude accuracy</b>	Doc no: Hitomi-MEMO-2016-001 Issue: 3.0
<b>Hitomi</b>		Date: December 7, 2016 Page: 1 of 15

**Title: Note on Hitomi attitude accuracy**

Prepared by:	Ryo Iizuka	ISAS/JAXA	Date:	December 7, 2016
	Shinya Nakashima	ISAS/JAXA		
	Yoshitomo Maeda	ISAS/JAXA		
	Yoh Takei	ISAS/JAXA		
Checked by:	Manabu Ishida		Date:	December 7, 2016
Agreed by:			Date:	
Authorized by:	Manabu Ishida		Date:	December 7, 2016

**Document change record**

Issue	Date	Changed section	Description of change
3.0	2016-12-07	Appendix E, etc	Reflected the change in the final (3rd) pipeline release (Dec 2016)
2.1	2016-09-20	—	Small correction
2.0	2016-09-18	Appendix D, etc	Reflected the change in 2nd pipeline release (Sep 2016)
1.1	2016-08-29	—	Small correction
1.0	2016-08-24	—	Official release

	<b>Note on Hitomi attitude accuracy</b>	Doc no: Hitomi-MEMO-2016-001 Issue: 3.0
<b>Hitomi</b>		Date: December 7, 2016 Page: 2 of 15

## Contents

<b>References</b>	<b>2</b>
<b>1 Introduction</b>	<b>3</b>
<b>2 Summary of attitude accuracy</b>	<b>3</b>
<b>3 Recipe to pick-up STT available duration</b>	<b>4</b>
3.1 How to pick up duration STT is available for attitude determination . . . . .	6
3.2 How to pick up duration STT is used for attitude control . . . . .	6
<b>A ASTRO-H attitude system</b>	<b>7</b>
A.1 STT available and non-available observations . . . . .	7
A.2 On-ground pointing correction . . . . .	7
A.3 Comments on aberration corrections . . . . .	8
<b>B X-ray image analysis</b>	<b>9</b>
<b>C SXS field of view and observed targets</b>	<b>11</b>
<b>D Updates in the 2nd pipeline (Sep 2016)</b>	<b>13</b>
<b>E Updates in the 3rd pipeline (Dec 2016)</b>	<b>13</b>

## References

- [1] ASTH-199-04 ASTRO-H 指向管理条件書 (ASTRO-H Alignment control requirement) Version 2, 2010-10-26, NEC
- [2] ASTH-NT-D16025 ASTRO-H 「ひとみ」衛星地上姿勢決定作業作業報告書, 2016-06-10 NEC
- [3] Plot of Hitomi Attitude Accuracy (STT ON/OFF) (attachment of this document), version 5.3, 2016-12-06
- [4] ASTH-NT-D16098 ASTRO-H 「ひとみ」衛星地上姿勢決定作業作業その 2 報告書, 2016-11-21 NEC

 <b>Hitomi</b>	<b>Note on Hitomi attitude accuracy</b>	Doc no: Hitomi-MEMO-2016-001 Issue: 3.0 Date: December 7, 2016 Page: 3 of 15
--	---	---

## 1 Introduction

The requirement of ASTRO-H attitude control (on pointing direction) is summarized in Table. 1 [1]. Note that the requirement is defined while the STT is available to control the attitude. There is no specific requirement when the STT is not available (e.g, during Earth occultation of STT FoV). In addition, this requirement should be applicable for observations after the commissioning of AOCS (attitude and orbit control system) subsystem is finished. The spacecraft is not designed to aim at very high accuracy like Chandra or XMM.

Table 1: Requirement for Hitomi attitude control on pointing direction

	Absolute accuracy of image center	Attitude stability (variation in time)
Control accuracy (onboard)	SXS: 1.5 mm or 55'' ( $3\sigma$ ) from detector center	SXS: N/A
	SXI: 5.0 mm or 184'' ( $3\sigma$ ) from detector center	SXI: 10'' ( $3\sigma$ ) in 4 s
	HXI: 3.0 mm or 51'' ( $3\sigma$ ) from detector center	HXI: N/A
Determination accuracy (offline)	SXS: 20'' ( $3\sigma$ )	SXS: 20'' ( $3\sigma$ ) in one observation
	SXI: 20'' ( $3\sigma$ )	SXI: 20'' ( $3\sigma$ ) in one observation
	HXI: 20'' ( $3\sigma$ )	HXI: 20'' ( $3\sigma$ ) in one observation

Since the observation of Hitomi was terminated before AOCS commissioning was finished, it is highly desirable to obtain the attitude accuracy for available observations with the similar accuracy to that expected after AOCS commissioning was finished. Moreover, from science point of view, the data when STT was not available for attitude control are equally precious, and hence the better attitude accuracy during these periods is also desirable.

As of 1st pipeline release (released in June/July), the attitude accuracy is limited, in not only actual control (wobbling of actual spacecraft attitude) but also attitude determination accuracy (error in the pointing direction stored in the pipeline product compared to the actual pointing direction). It is partly because the AOCS was still under start-up and check-out, and partly because the attitude stored in the pipeline product was based on the first “trial” and hence correlation study with X-ray image was not performed.

In this document, the current attitude accuracy is summarized, along with related information. The data used in the analysis shown in this document are from 1st release, distributed from 2016-06-25 to 2016-08-01. The summary of the updates in the 2nd release (Sep 2016) and resultant accuracy/stability of the reconstructed attitude are shown in Appendix D. The summary of the updates in the 3rd (final) release (Dec 2016) and resultant accuracy/stability of the reconstructed attitude are shown in Appendix E. In Appendix E, the attitude accuracy and stability for each instrument are also shown when available, so that the difference among the instrument is seen.

## 2 Summary of attitude accuracy

Accuracy and stability of the attitude for each observation are evaluated using the distribution of observed X-ray photons from the analysis described in Appendix. B. The results in SKY coordinates (RA and Dec) are summarized in Table 2<sup>1</sup>. The accuracy value is the angular distance between the target coordinates (determined by SIMBAD database) and the center of the X-ray photon distribution. The stability value is the standard deviation of the distribution of the X-ray image center taken from short intervals (60 s or 300 s). Note that the value of stability is affected by the error (uncertainty) in determining the center of X-ray distribution. Since the photon statistics of IGR J16318-4848 and RXJ 1856.5-3754 observations is low, the stability values of these observations are likely affected (degraded) by the error of X-ray image center location.

During Hitomi observations, STT is sometimes available and used for onboard attitude control, but sometimes not. Actually the following three cases appear in all observations.

<sup>1</sup>The values of Table 2 is revised for Issue 2.0 from Issue 1.1.

 <b>Hitomi</b>	<b>Note on Hitomi attitude accuracy</b>	Doc no: Hitomi-MEMO-2016-001 Issue: 3.0 Date: December 7, 2016 Page: 4 of 15
--	---	---

Table 2: Accuracy and stability of attitude for the SCT 1st release data (distributed on Jun 25 – Aug 1)

Target	OBSID	Instrument <sup>§</sup>	STT controlled		STT available		STT unavailable	
			Acc.*	Stb.†	Acc.*	Stb.†	Acc.*	Stb.†
Perseus_core‡	100040010	SXS	-	-	-	-	-	-
Perseus_core_adjustment	100040020	SXS	12.6	4.9	9.3	6.1	14.4	8.8
Perseus	100040030	SXS	11.6	5.6	8.5	7.7	20.3	7.6
”	100040040	SXS	12.3	6.1	8.8	9.7	21.5	8.8
”	100040050	SXS	19.4	7.1	12.0	8.6	11.5	8.7
Perseus_adjustment	100040060	SXS	24.9	5.3	24.8	7.0	31.4	8.1
N132D	100041010	SXI	23.4	2.0	23.8	23.8	N/A	N/A
”	100041020	SXI	22.1	7.7	21.8	7.8	20.8	7.4
IJR_J16318-4848	100042040	SXI	7.9	7.3	7.7	8.0	15.2	8.6
RXJ1856.5-3754	100043010–40	SXI	35.4	8.0	40.0	7.4	11.8	6.6
G21.5-0.9	100050010	SXS	8.9	4.9	9.5	5.9	10.7	10.2
”	100050020	SXS	9.0	4.9	10.1	6.3	14.9	11.0
”	100050030	SXS	9.1	4.8	9.3	4.9	17.0	12.3
”	100050040	SXS	8.9	5.0	9.4	5.9	13.5	8.7
”	100050050	SXS	6.7	2.5	10.2	6.1	N/A	N/A
RXJ1856.5-3754	100043050	SXI	18.4	9.2	18.6	9.3	17.1	7.0
”	100043060	SXI	18.8	9.3	19.2	8.8	21.1	6.1
Crab	100044010	SXS	4.4	3.1	4.4	3.3	20.6	6.5

NOTE: values for the 2nd and 3rd release data are shown in Table 4 and 5, respectively.

<sup>§</sup> Instrument used for the analysis.

\* Accuracy of image center in the unit of arcsecond.

† Stability of attitude ( $1\sigma$ ) in the unit of arcsecond.

‡ Cannot evaluate attitude because the center of Perseus is not in the SXS FOV.

1. One of STTs is used for onboard attitude control. The attitude control accuracy is good and attitude determination accuracy is good.
2. (One or two of) STT is available for offline attitude determination, but not used for onboard attitude control. The attitude control accuracy is not good and attitude determination accuracy is good.
3. None of STT is available for attitude determination (e.g., Earth occultation of two STT FoVs) nor attitude control. The attitude control accuracy is not good and attitude determination accuracy is not good.

The Table 2 shows accuracy and stability for these three cases separately. The accuracy and stability of “STT unavailable” is significantly worse than the other two in most observations. While the stability of “STT available” should be worse than “STT controlled” in DET coordinates, the values in SKY coordinates are similar as shown in the Table. Note that Table 2 is for the data of 1st pipeline release. The information for the 2nd and 3rd pipeline release are shown in Table 4 and 5, respectively.

### 3 Recipe to pick-up STT available duration

Since the attitude determination or control accuracy depends on STT availability, one may want to pick up X-ray photons only while the STT is available (either determination or control), in order to obtain X-ray data for better attitude accuracy, with sacrifice of photon statistics (X-rays for other durations will be discarded). In such a science case that the attitude accuracy is more important than photon statistics, a user may extract X-ray events while the STT is available by HK parameters as shown in Table 3, from `ah${SEQ_NO}gen_a0.hk` file. Note that the cleaned events in the pipeline contain all the data shown in the three rows of Table 3, i.e.,

 <b>Hitomi</b>	<b>Note on Hitomi attitude accuracy</b>	Doc no: Hitomi-MEMO-2016-001 Issue: 3.0 Date: December 7, 2016 Page: 5 of 15
--	---	---

all of “STT is not used for attitude determination nor control”, “STT is used for attitude determination”, and “STT is used for attitude control”. If a user does not need additional attitude accuracy, the data selection shown in this section is not recommended because the selection leads to smaller statistics.

Table 3: Parameters to pick up X-ray photons while the STT is available.

Telemetry of ah $\$/SEQ\_NO$ gen\_a0.hk

	Extension [HK_ACPA_PD_DATA_4HZ_1]	Extension [HK_ACPA_HK_NOM]	Extension [HK_ACPA_AOCS_HK_NM_CHECKOUT_1HZ_1]
STT is not used for attitude determination nor attitude control	ACPA_STT1_Q_VALID==0 && ACPA_STT2_Q_VALID==0	N/A	N/A
STT is used for attitude determination	ACPA_STT1_Q_VALID==1    ACPA_STT2_Q_VALID==1	N/A	N/A
STT is used for attitude control	ACPA_STT $\$/STTSEL$ _Q_VALID==1	ACPA_CONT_MODE==6 && ACPA_CONT_SUB_MODE==2 && ACPA_STT $\$/STTSEL$ _INTF_STS==0 && ACPA_FDIR_COMP_STT $\$/STTSEL$ _ID_ERR_FLG==0	ACPA_ADS_STT_STS==1 && ACPA_ADS_KF_UP==1

$\$/STTSEL$  is ACPA\_ADS\_STT\_SEL in Extension [HK\_ACPA\_AOCS\_HK\_NM\_CHECKOUT\_1HZ\_1]

Examples of a script to pick up X-ray photons while the STT is used for attitude determination or attitude control are as follows.



Hitomi

## Note on Hitomi attitude accuracy

Doc no: Hitomi-MEMO-2016-001  
Issue: 3.0  
Date: December 7, 2016  
Page: 6 of 15

### 3.1 How to pick up duration STT is available for attitude determination

```
#!/bin/bash
```

```
seq_num=100044010
gen_hk_file=./ah${seq_num}gen_a0.hk
gti_out_file=gti_stt_determination.fits

ahgtigen "infile=${gen_hk_file}[HK_ACPA_PD_DATA_4HZ_1]" "outfile=${gti_out_file}" \
'gtifile=none' "gtiexpr=(ACPA_STT1_Q_VALID==1)||(ACPA_STT2_Q_VALID==1)" \
'mergegti=and' 'leapsecfile=none' 'instrume=sxs' 'chatter=2' \
'clobber=yes' 'logfile=test.log'
```

### 3.2 How to pick up duration STT is used for attitude control

```
#!/bin/bash
```

```
seq_num=100044010
gen_hk_file=./ah${seq_num}gen_a0.hk
stt_sel=2
gti_out_file=gti_stt_control.fits

### Remove TNULL rows from each extension ###
ftcopy "infile=${gen_hk_file}[HK_ACPA_HK_NOM][col *][ACPA_CONT_MODE<255]" \
'clobber=yes' 'copyall=no' 'outfile=hk_1.fits.tmp'
ftcopy "infile=${gen_hk_file}[HK_ACPA_AOCS_HK_NM_CHECKOUT_1HZ_1][col *][ACPA_ADS_STT_STS<255]" \
'clobber=yes' 'copyall=no' 'outfile=hk_2.fits.tmp'

### Create GTI for each extension ###
ahgtigen "infile=hk_1.fits.tmp[HK_ACPA_HK_NOM]" 'outfile=gti_stt_1.fits.tmp' 'gtifile=none' \
"gtiexpr=(ACPA_CONT_MODE==6)&&(ACPA_CONT_SUB_MODE==2)&&(ACPA_STT${stt_sel}_INTF_STS==0) \
&&(ACPA_FDIR_COMP_STT${stt_sel}_ID_ERR_FLG==0)" 'mergegti=and' 'leapsecfile=none' \
'instrume=sxs' 'chatter=2' 'clobber=yes' 'logfile=test.log'

ahgtigen "infile=hk_2.fits.tmp[HK_ACPA_AOCS_HK_NM_CHECKOUT_1HZ_1]" \
'outfile=gti_stt_2.fits.tmp' 'gtifile=none' \
'gtiexpr=(ACPA_ADS_STT_STS==1)&&(ACPA_ADS_KF_UP==1)' 'mergegti=and' 'leapsecfile=none' \
'instrume=sxs' 'chatter=2' 'clobber=yes' 'logfile=test.log'

ahgtigen "infile=${gen_hk_file}[HK_ACPA_PD_DATA_4HZ_1]" 'outfile=gti_stt_3.fits.tmp' \
'gtifile=none' "gtiexpr=(ACPA_STT${stt_sel}_Q_VALID==1)" 'mergegti=and' \
'leapsecfile=none' 'instrume=sxs' 'chatter=2' 'clobber=yes' 'logfile=test.log'

### Merge GTI file created from each extension ###
## First create a list
cat <<EOF > gti_stt.lst.tmp
gti_stt_1.fits.tmp
gti_stt_2.fits.tmp
gti_stt_3.fits.tmp
EOF

## Then, merge
ahgtigen 'infile=NONE' "outfile=${gti_out_file}" 'gtifile=@gti_stt.lst.tmp' \
'gtiexpr=NONE' 'mergegti=AND' 'clobber=yes' 'chatter=2'

### Remove intermediate files ###
rm -f hk_[12].fits.tmp gti_stt_[123].fits.tmp gti_stt.lst.tmp
```

	<b>Note on Hitomi attitude accuracy</b>	Doc no: Hitomi-MEMO-2016-001 Issue: 3.0 Date: December 7, 2016 Page: 7 of 15
<b>Hitomi</b>		

## A ASTRO-H attitude system

ASTRO-H is in many aspects similar to Suzaku in terms of attitude controlling. The spacecraft attitude is stabilized by four sets of reaction wheels, while the attitude is measured by three gyroscopes (IRUs) and two star trackers (STTs) (see Fig. 1 for locations). The accumulated angular momentum is removed by magnetic torquers that interact with the Earth’s magnetic field.

Since the satellite revolves in a near-earth orbit, most targets are occulted by the Earth for about one third of each orbit, but some objects near the orbital poles can be observed nearly continuously. Observation is also interrupted by passages of the South Atlantic Anomaly. The similar interrupt is also made for the STTs, too.

The field of view of the STTs is close to the X-ray telescopes and hence it covers that of the X-ray instruments (SXS,SXI,HXI and SGD; see Figure 2). The STTs are designed to track the stars as long as possible when the X-ray telescopes watch celestial objects (visible) (it is improvement from Suzaku). However, since the field of view of STTs is much larger than that of the X-ray instruments, the allocation of the “cone” angles for the earth’s occultation and earth’s stray light for the STTs is also much larger than the field of view of the X-ray instruments, as large as 20 degrees. Therefore, STT is not available for all periods when celestial objects are visible by X-ray telescopes.

The duration that the STTs track the stars gives a good pointing accuracy (see § 2), while the duration when the STTs do not track the stars is expected to show worse pointing accuracy. The field of view of the STTs are tilted by 5 degrees from the satellite Z-axis. The tilt direction of the STTs’ axes are not the same each other. The duration of the earth occultation of the STT1 and STT2 are then not the same, too.

### A.1 STT available and non-available observations

Fig. 2 demonstrate schematics of the STT available or non-available observations. For more than the half of the X-ray visibility, the attitude is controlled by the STTs (the case (a) in Fig. 2 ). Since the STTs attitude accuracy is as good as arcsecs in order, the pointing accuracy of the X-ray system is also good in the same order (see Table 2). However, since the cone angle of the STTs are larger than those of the X-ray instruments, the low-earth-elevation observations are sometimes controlled without the STTs.

In most of the observations, the earth occultation occurs every orbit. The low-elevation observations is then made at the egress and/or the ingress of the earth occultation of the of each orbit. The STTs tracking is ended near the ingress. The AOCU tries to keep its attitude stable referring to the IRUs. Usually, the pointing is still stable close the ingress, while the attitude error becomes larger at the egress since the attitude control was done by using only IRU information for a long time. The STT detects the pointing shift at the egress (when the STT becomes available) and the position of the X-ray source is corrected rapidly.

If the pointing is stable, there should be no shift of the target position in the detector coordinates (i.e., the RAW, ACT, DET, FOC coordinates.). Therefore, the stability is usually confirmed in these coordinates at the duration of the STTs-available and the ingress of the earth occultation. The pointing at the egress of the occultation is unstable sometimes.

### A.2 On-ground pointing correction

The conversion to the sky coordinates (the SKY coordinates) of the X-ray instruments are remade on ground by using a pre-pipeline attitude software. Since the observations of the ASTRO-H were made during the commissioning phase of the AOCs system including the IRUs, bias of the gyros (so-called “drift rates”) are not yet calibrated well. We have to reconstruct the pointing direction by referring to the non-calibrated gyros when the STTs are not available. This situation makes increase the error of the pointing of the STT non-available durations.

While the STT is not available, the attitude is traced by time integration of gyros’ angular velocity readings. They, however, bear some bias which are different from observation to observation. Now we ignore the difference of the bias, some observations have relatively large attitude error while others do not.

	<b>Note on Hitomi attitude accuracy</b>	Doc no: Hitomi-MEMO-2016-001 Issue: 3.0 Date: December 7, 2016 Page: 8 of 15
<b>Hitomi</b>		

The attitude reconstruction algorithm used in the 1st pipeline data estimates the attitude “backwards” in time domain (by Kalman filter algorithm). This asymmetry in time results in non-uniform attitude error in time. Actually, the largest errors occur at the STT IN→OUT moments (ingress of the occultation), because the uncertainty when STT is unavailable is most accumulated at the moments, since the estimate is done reverse in time. Consequently, the source position in the SKY coordinates is wrongly corrected at the ingress of the earth occultation. At the egress, the stability pointing is often improved in the SKY coordinate. This is illustrated in Figure 3 in § B. Note that this was improved in the 2nd pipeline data, by using the weighted mean of “backward” and “forward” estimate. See Appendix D for details.

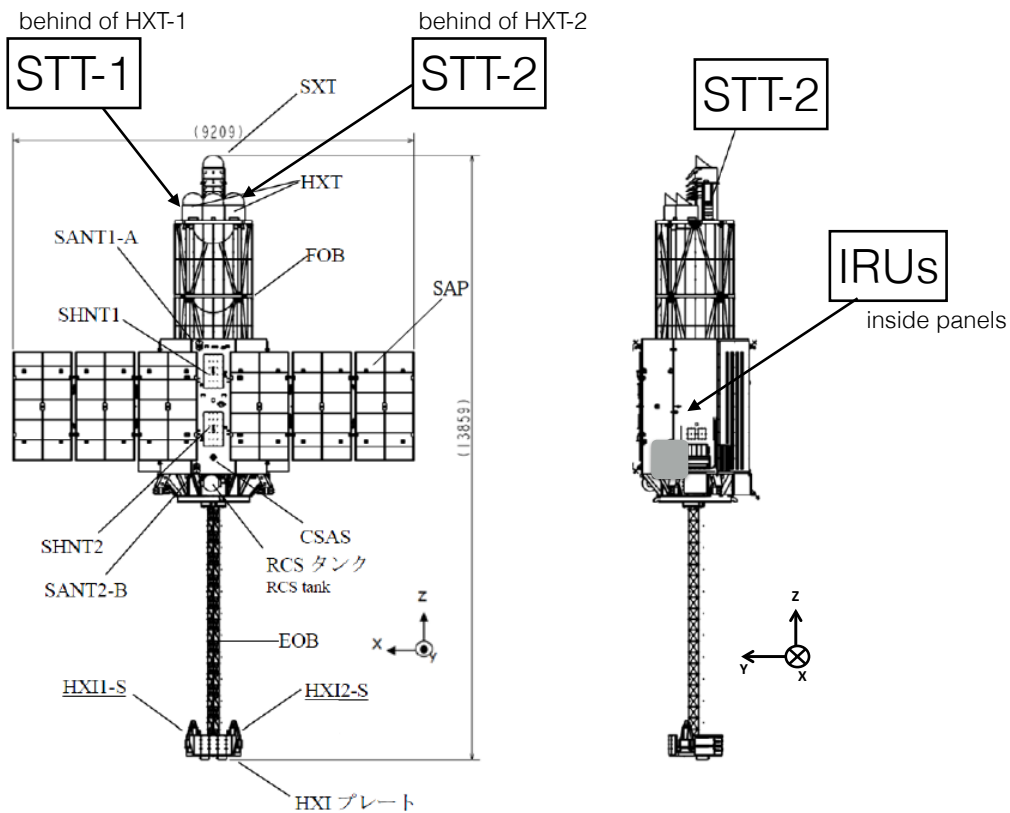

Figure 1: Location of instruments of AOCS

### A.3 Comments on aberration corrections

The ASTRO-H attitude system is designed to handle the aberration effect on orbit. At the launch, the AOCU onboard system started without the aberration correction. The parameters in the AOCU system were gradually changed to correct the aberration and was finished about a month later. The pre-pipeline attitude software used in the 1st pipeline release does not fully account for each step of the parameter changes<sup>2</sup>. The aberration due to the motion of the Earth was properly taken into account in the 2nd pipeline release, and the aberration

<sup>2</sup> The pipeline software built by SCT has the function to correct the aberration of incoming X-rays, provided that the spacecraft attitude was properly determined by the attitude system and the pre-pipeline software. When AOCU onboard system does not handle the aberration effect as designed in the nominal mode, the spacecraft attitude is incorrectly estimated, requiring additional correction.



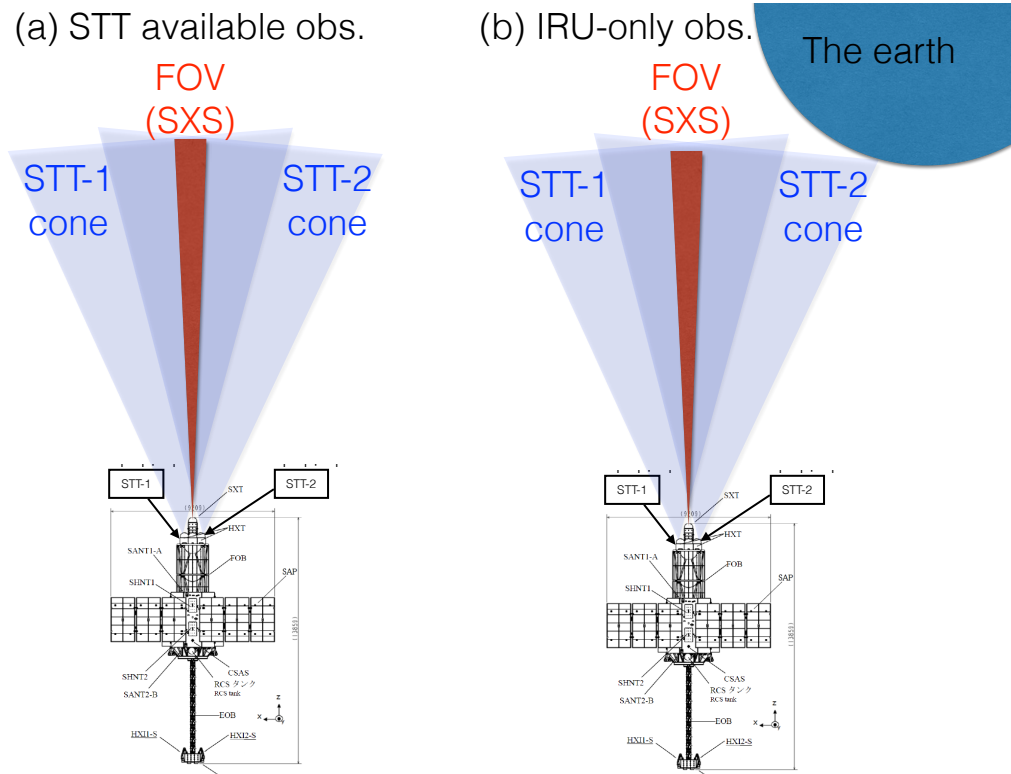

Figure 2: (a) An example of the STT available observation. Both of the two STTs cone and the X-ray FOV do not watch the earth rim. The attitude is primarily controlled by the star pattern in the STTs. (b) An example of the STT non-available observation. Both of the STTs' cone covers the earth rim whereas the X-ray FOVs do not. The attitude is controlled by relying the IRUs (gyros) only.

due to the satellite motion around the Earth was in addition taken into account in the 3rd pipeline release. See Appendix D and E.

## B X-ray image analysis

The attitude accuracy shown in § 2 is determined as follows. Detailed results are shown in the attachment [3].

The attitude accuracy is estimated using the distribution of observed X-ray photons. The “accuracy” of the reconstructed attitude is determined by fitting an X-ray image from the whole exposure in SKY coordinates with a 2-dimension Lorentzian profile. On the other hand, the “stability” is determined by calculating the variation of the center position in the short intervals using median 50 percentile. The center of the photon distribution, along with the statistical error is determined for every 300 s interval (60 s interval is used for Crab, because the statistics is high enough). The center position is taken as a median 50 percentile (by python `media_grouped` function) in both DET and SKY coordinates. Since it is known that the attitude control/determination accuracy is different by STT status, the values in the three STT status shown in § 2 are determined separately.

The movement of the center position of each interval in DET coordinates indicates the attitude wobbling or attitude control accuracy, while the movement in SKY coordinates corresponds to attitude determination accuracy. These values are compared to the attitude file values in order to verify the accuracy of the attitude determination.

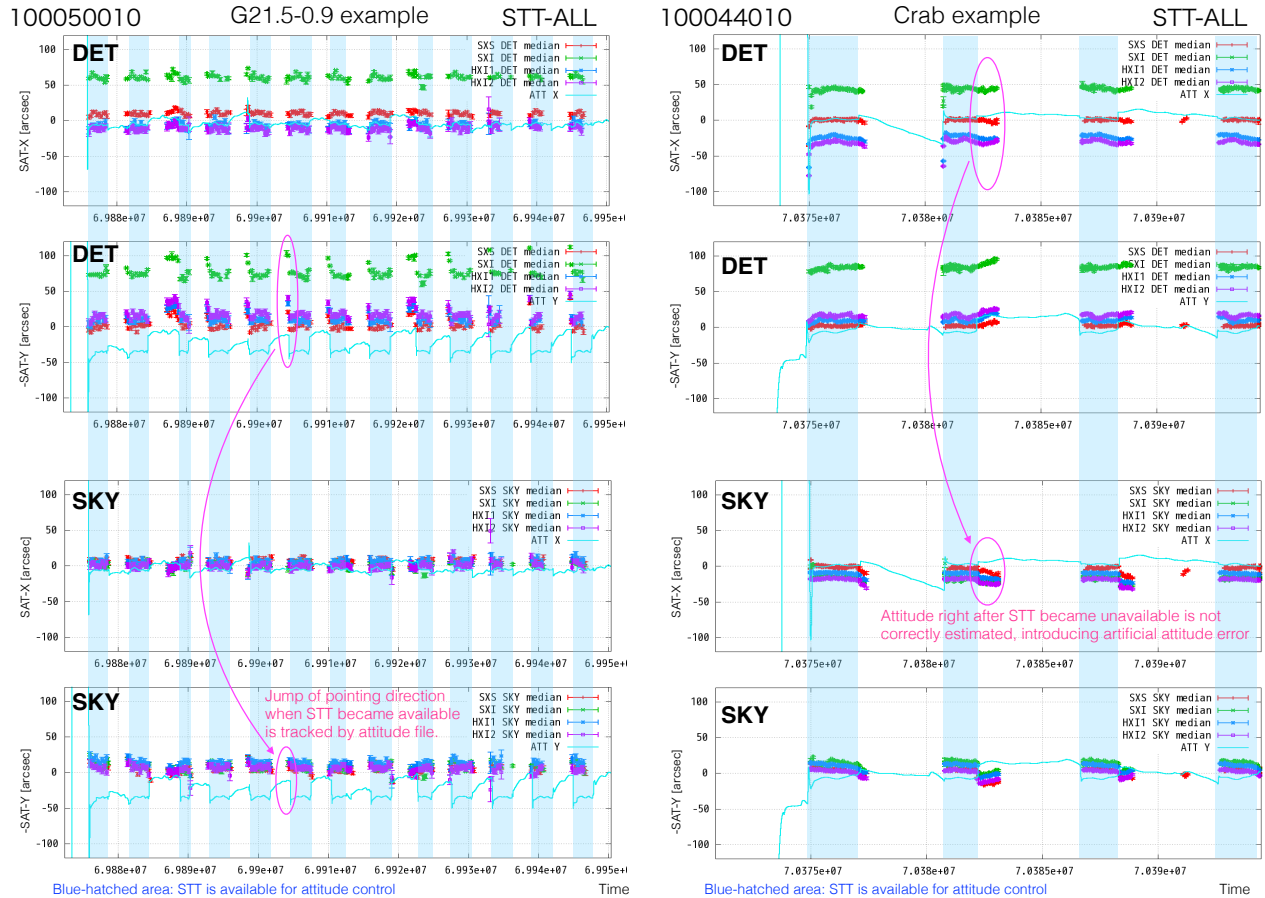



Figure 3: Examples of X-ray image analysis using the 1st pipeline data distributed from 2016-06-25 to 2016-08-01: G21.5-0.9 (left) and Crab (right) observations. Red, green, blue and purple data points are X-ray image center taken by SXS, SXI, HXI1 and HXI2, respectively, while the light-blue line shows the attitude data taken from att file. Top two panels shows the X-ray photon position taken in DET coordinates, while bottom two panels shows the position taken in SKY coordinates. Both DET and SKY data are converted in SAT coordinates and then plotted in SAT-X (upper) and -SAT-Y (lower) coordinates. Blue-hatched region indicates the duration when STT is available for attitude control. It is known that the attitude sometimes shows a “jump” when STT becomes available for attitude control, or when STT becomes unavailable for attitude determination. The former corresponds to the actual attitude jump, as is visible in the example of G21.5-0.9, which is a result of adjusting spacecraft pointing to correct attitude error accumulated when STT is unavailable, while the latter is an artifact due to incorrect attitude estimate, as is visible in the example of Crab. In the former case, attitude fluctuation in SKY coordinates is better (smaller) than in DET coordinates, while in the latter case, that in DET coordinates is better.

It is known that the attitude determined sometimes shows “jumps”. There are two patterns: one occurs when STT becomes available for attitude control after long STT-unavailable time (egress of the occultation), while the other occurs when the STT becomes unavailable for attitude determination (ingress of the occultation). For better looking and understanding, two examples from [3] are shown in Figure 3. Left panels show data of G21.5-0.9 observation, while the right panels Crab. Blue hatched regions are while STT is available for attitude control.

	<b>Note on Hitomi attitude accuracy</b>	Doc no: Hitomi-MEMO-2016-001 Issue: 3.0
<b>Hitomi</b>		Date: December 7, 2016 Page: 11 of 15

In the G21.5-0.9 (left) case, attitude jumps when STT becomes available are seen. They are clearly seen with the second row (data points taken from DET coordinates), while they are less apparent with the fourth row (data points taken from SKY coordinates). It indicates that the jumps seen in DET coordinates are actual attitude jumps, which are the result of onboard adjustment of spacecraft pointing to correct attitude error accumulated when STT is unavailable.

In the Crab (right) case, attitude jumps when STT becomes unavailable are observed. They are more visible in SKY coordinates than DET coordinates. It indicates that the jumps of attitude are not real, but an artifact; the attitude estimate is incorrect and spurious jumps are introduced. It is known that the attitude error introduced by the attitude-determination algorithm of the 1st pipeline release is largest when STT becomes unavailable. This is the reason why the jumps appear at the time when STT became unavailable.

The interpretation of attitude jumps are also applicable for other observations. In general, the attitude jumps when STT became unavailable are likely artifacts, while the jumps when STT became available are real as discussed in § A.2. The amplitude of jumps are different among observations. See [3] to check for other observations.

The 2nd pipeline data distributed in Sep 2016 uses modified attitude reconstruction algorithm, which removed the artificial jump when STT becomes unavailable. See Appendix D for comparison.

## C SXS field of view and observed targets

The SXS field of view overlaid with Chandra or XMM image of each observed target is shown in Figure 4. As seen in Figure 4, in some cases, the object is not in the SXS FoV, because the pointing direction was not correct. Note that there is attitude wobbling in the actual observation, which is not taken into account making the images in Figure 4.

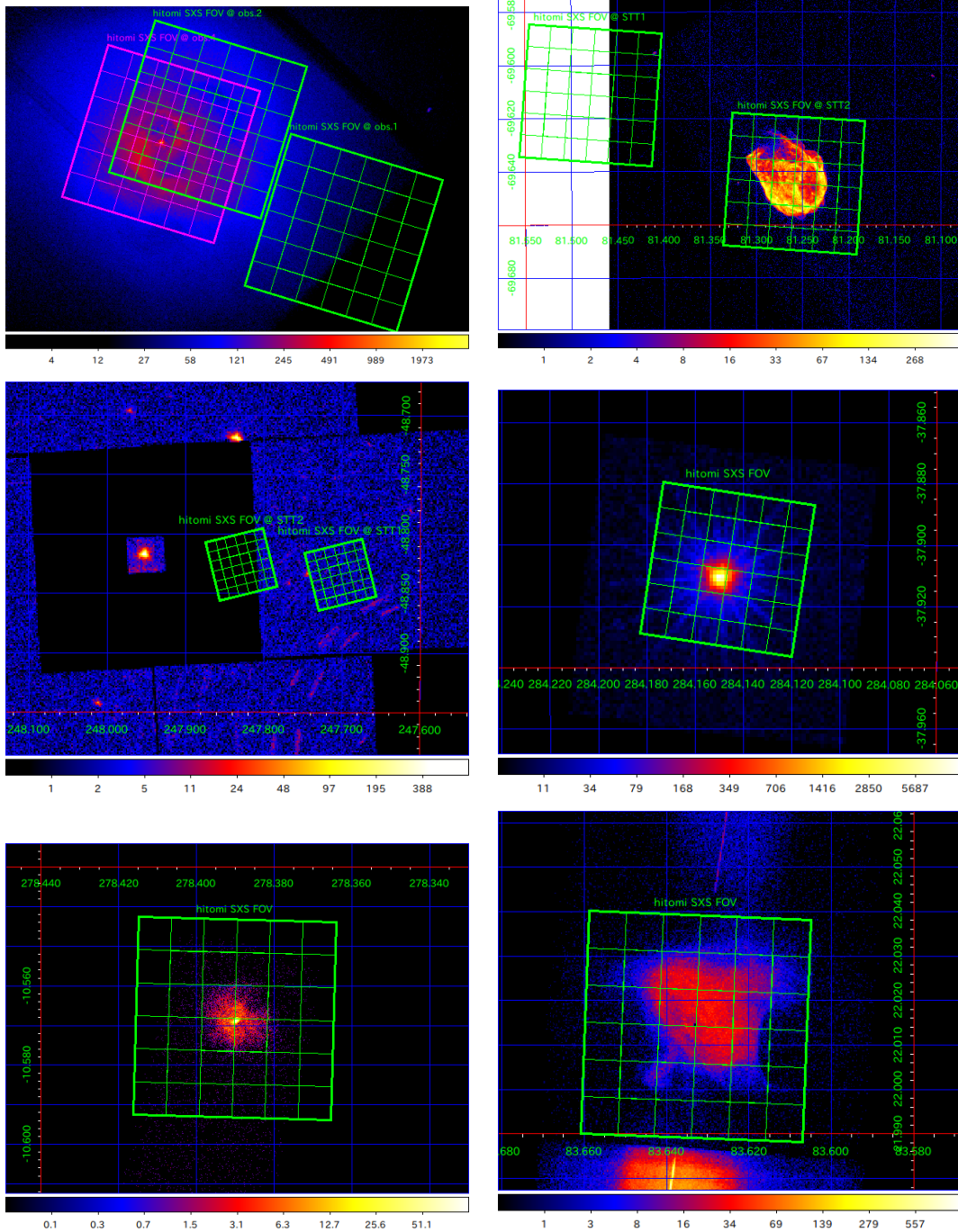

Figure 4: The SXS field of view overlaid with Chandra or XMM image (images by Kosuke Sato). Top: Perseus (left) and N132D (right); middle: IGR J16318-4848 (left) and RXJ 1856.5-3754 (right); bottom: G21.5-0.9 (left) and Crab (right). In some cases, the object is not in the SXS FoV, because the pointing direction was not correct.

## D Updates in the 2nd pipeline (Sep 2016)

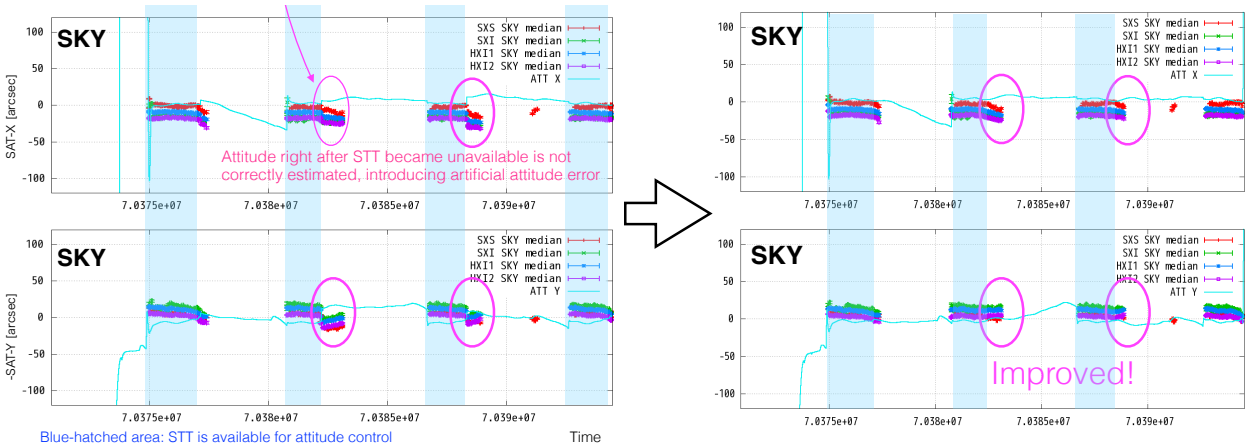

Figure 5: Comparison of the reconstructed attitude in SKY coordinates between the 1st pipeline release (left) and the 2nd pipeline release (right).

For the 2nd pipeline release (will be distributed in Sep 2016), the attitude reconstruction was updated in order

- to change the attitude reconstruction algorithm to avoid the artificial jump when STT becomes unavailable (c.f., § B).
- to properly correct the aberration due to the motion of the Earth around the Sun for all observations. Note that the aberration due to the satellite motion was still not correct for some observations because of the non-nominal AOCS modes.

The accuracy and stability of the attitude reconstruction of the data of 2nd pipeline release is shown in Table 4. The values are estimated with the same method as § B.

The improvement in the accuracy is mainly by change of aberration correction, while the improvement in the stability is mainly by changing the reconstruction algorithm. Figure 5 compares the reconstructed attitude of the Crab observation between the 1st (left) and 2nd (right) pipeline release, showing the improvement. The new algorithm estimates the attitude using the weighted mean of the result of “backward” processing and “forward” processing in time domain, while the previous one uses only “backward” algorithm.

## E Updates in the 3rd pipeline (Dec 2016)

For the 3rd pipeline release (will be distributed in Dec 2016), the attitude reconstruction was further updated. In addition to the revision made for the 2nd pipeline release, this revision includes:

- proper correction of the aberration, even for the observations when the function of onboard aberration correction was not enabled. The correction includes not only the aberration due to the motion of the Earth around the Sun, but also the motion of the satellite around the Earth.
- improvement of the calibration of STT1 pointing direction in the satellite coordinates.

 <b>Hitomi</b>	<b>Note on Hitomi attitude accuracy</b>	Doc no: Hitomi-MEMO-2016-001 Issue: 3.0 Date: December 7, 2016 Page: 14 of 15
--	---	--

Table 4: Accuracy and stability of attitude for the SCT 2nd release data.

Target	OBSID	Instrument <sup>§</sup>	STT controlled		STT available		STT unavailable	
			Acc.*	Stb.†	Acc.*	Stb.†	Acc.*	Stb.†
Perseus_core <sup>‡</sup>	100040010	SXS	-	-	-	-	-	-
Perseus_core_adjustment	100040020	SXS	6.9	5.0	3.4	6.2	10.8	10.3
Perseus	100040030	SXS	5.9	5.6	4.9	7.7	14.4	12.7
"	100040040	SXS	6.4	5.9	5.8	9.3	14.5	12.1
"	100040050	SXS	12.6	7.4	6.8	8.9	23.6	7.1
Perseus_adjustment	100040060	SXS	16.4	5.6	17.1	8.3	21.9	11.0
N132D	100041010	SXI	3.1	1.9	5.7	23.9	N/A	N/A
"	100041020	SXI	3.4	7.5	3.4	7.7	3.3	4.3
IGR_J16318-4848	100042040	SXI	5.4	7.4	5.5	8.1	6.4	7.9
RXJ1856.5-3754	100043010–40	SXI	20.8	8.0	30.6	7.5	10.1	5.5
G21.5-0.9	100050010	SXS	9.1	4.9	9.3	5.5	7.5	7.5
"	100050020	SXS	9.1	4.8	9.7	5.8	11.4	7.7
"	100050030	SXS	9.2	5.0	9.3	5.0	11.0	6.2
"	100050040	SXS	9.3	4.9	9.6	5.6	11.0	7.2
"	100050050	SXS	13.9	3.3	13.3	3.2	N/A	N/A
RXJ1856.5-3754	100043050	SXI	19.0	9.3	17.8	9.4	17.3	6.9
"	100043060	SXI	18.7	9.3	19.0	8.7	22.0	5.9
Crab	100044010	SXS	4.5	2.9	3.4	3.1	9.1	4.2

<sup>§</sup> Instrument used for the analysis.

\* Accuracy of image center in the unit of arcsecond.

† Stability of attitude ( $1\sigma$ ) in the unit of arcsecond.

<sup>‡</sup> Cannot evaluate attitude because the center of Perseus is not in the SXS FOV.

The resultant attitude accuracy and stability are summarized in Table 5. The accuracy and stability of each available instrument, extracted from the cleaned data regardless of the STT availability, are shown in Table 6. The event data for all “STT controlled”, “STT available” and “STT unavailable” in Table 5 are combined to calculate the values in Table 6.

 <b>Hitomi</b>	<b>Note on Hitomi attitude accuracy</b>	Doc no: Hitomi-MEMO-2016-001 Issue: 3.0 Date: December 7, 2016 Page: 15 of 15
--	---	--

Table 5: Accuracy and stability of attitude for the SCT 3rd release data.

Target	OBSID	Instrument <sup>§</sup>	STT controlled		STT available		STT unavailable	
			Acc.*	Stb.†	Acc.*	Stb.†	Acc.*	Stb.†
Perseus_core <sup>‡</sup>	100040010	SXS	-	-	-	-	-	-
Perseus_core_adjustment	100040020	SXS	8.8	4.8	6.9	5.7	2.3	7.4
Perseus	100040030	SXS	8.3	4.8	4.9	6.0	6.9	8.9
”	100040040	SXS	8.4	5.2	4.5	7.5	5.6	8.7
”	100040050	SXS	17.2	6.4	9.9	7.8	15.2	10.0
Perseus_adjustment	100040060	SXS	18.0	4.0	17.6	4.7	16.8	8.0
N132D	100041010	SXI	1.3	1.8	2.9	26.7	N/A	N/A
”	100041020	SXI	6.2	7.2	5.6	7.2	6.2	4.8
IGR_J16318-4848	100042040	SXI	7.1	7.1	6.6	7.4	4.7	7.9
RXJ1856.5-3754	100043010–40	SXI	22.7	8.0	23.7	7.3	20.2	5.0
G21.5-0.9	100050010	SXS	8.4	4.4	8.4	5.0	5.5	6.8
”	100050020	SXS	8.5	4.6	8.6	5.0	6.6	6.3
”	100050030	SXS	8.4	4.8	8.4	4.6	7.2	4.9
”	100050040	SXS	7.8	5.1	7.8	5.2	6.1	7.4
RXJ1856.5-3754	100043050	SXI	16.3	9.2	16.8	9.4	20.4	6.2
”	100043060	SXI	16.8	9.3	17.2	8.8	19.5	6.0
Crab	100044010	SXS	0.2	2.9	0.1	3.0	3.3	4.0

<sup>§</sup> Instrument used for the analysis.

\* Accuracy of image center in the unit of arcsecond.

† Stability of attitude ( $1\sigma$ ) in the unit of arcsecond.

‡ Cannot evaluate attitude because the center of Perseus is not in the SXS FOV.

Table 6: Summary of attitude accuracy/stability for all the instruments in the SCT 3rd release data.

Target	OBSID	Accuracy				Stability			
		SXS	SXI	HXI1	HXI2	SXS	SXI	HXI1	HXI2
Perseus_core <sup>‡</sup>	100040010	-	-	-	-	-	-	-	-
Perseus_core_adjustment	100040020	4.0	-	-	-	6.2	-	-	-
Perseus	100040030	1.1	-	-	-	7.6	-	-	-
”	100040040	0.9	-	-	-	7.8	-	-	-
”	100040050	5.9	-	-	-	12.6	-	-	-
Perseus_adjustment	100040060	17.1	6.1	-	-	6.0	5.4	-	-
N132D	100041010	-	3.4	-	-	-	26.5	-	-
”	100041020	-	6.8	-	-	-	7.0	-	-
IGR_J16318-4848	100042040	-	5.7	-	-	-	8.0	-	-
RXJ1856.5-3754	100043010–40	-	22.5	-	-	-	6.7	-	-
G21.5-0.9	100050010	8.2	3.8	3.6	3.8	5.2	6.1	5.2	7.4
”	100050020	8.4	4.3	3.4	4.9	5.0	6.0	4.6	6.1
”	100050030	8.1	4.3	3.4	5.0	4.7	5.7	4.9	5.4
”	100050040	7.7	3.1	3.9	5.2	5.5	5.1	5.1	5.2
RXJ1856.5-3754	100043050	-	17.7	-	-	-	9.0	-	-
”	100043060	-	18.3	-	-	-	8.6	-	-
Crab	100044010	0.2	15.7	10.2	13.6	3.6	4.0	2.5	2.2